



MEMORANDUM

February 3, 2026

TO: Maunakea Management Board
FROM: Greg Chun, Executive Director, Center for Maunakea Stewardship (CMS)
SUBJECT: Subaru Lower Dome Re-coating and Replace Upper Exhaust Vents, Site Plan application

- | |
|---|
| <ul style="list-style-type: none"> • Proposal rec'd: 12/8/2025 • Type A B/ C • CMS project #364 • ED review: 12/29/2025 • EC: 1/8/2026 • KKM: Three-Year Plan review • MKMB: 2/3/2026 • MKSOA: 2/12/2026 |
|---|

I. Project Description

Subaru requests to recoat part of its telescope facility and to replace two, roof-mounted exhaust outlets. The activities are considered repair work that is necessary to address storm damage. Subaru was originally approved under Conservation District Use Permits (CDUP) HA 2462.

Due to the placement for more than thirty days of structures including dumpsters for this work, CMS proposes the applicable land use as HAR §13-5-22, Protective subzone, P-9, Structures, Accessory (B-1) *Construction or placement of structures accessory to existing facilities or uses*, requiring Site Plan Approval. This land use triggers a Type B designation as defined by the 2022 Master Plan for the University of Hawaii Maunakea Lands. CMS notes that the bulk of work activity is otherwise limited to the existing infrastructure of Subaru's permitted facility and identifies the relevant land use as HAR §13-5-22, P-8, Structures and Land Uses, Existing (A-1) *Minor repair, maintenance, and operation to an existing structure, facility, use, land, and equipment... that involves mostly cosmetic work or like-to-like replacement of component parts, and that results in negligible change to or impact to land, or a natural and cultural resource.*

II. Historical and Cultural Resources Identified

The project area is located within the following identified historic properties:

- Kūkahau'ula Traditional Cultural Property, State Inventory of Historic Places (SIHP) Site #50-10-23-21438.
- Mauna Kea Summit Region Historic District, SIHP Site #26869;
- Mauna A Wākea Traditional Cultural Property and District, SIHP Site #31382; and

The site geology is composed of varying depths of volcanic ash, cinder, and clinkers over native Hawaiite flows. Lake Waiau, the nearest freshwater body, is over one mile from the project site, over porous and hilly terrain. Sparse lichen and/or moss may occur at the project site. No rare, threatened, or endangered plant, arthropod, or animal species have been documented at the site. Recreational visitors stop by the site, primarily at sunset for sightseeing.



III. Impacts Identified

The proposed work is limited to existing infrastructure and will not enlarge Subaru's footprint, nor change or extend the permitted use of the facility. The applicant does not anticipate any ground disturbance, change or increase in footprint or approved use, nor any impacts to the surrounding landscape or other natural (biological, geological, hydrological), historical, cultural, recreational, or scientific resources, and is expected to have negligible impact on any resources.

IV. Recommended Mitigation

CMS recommends Best Management Practices and other project conditions be adhered to in carrying out this work. The project will not proceed unless and until the Office of Conservation and Coastal Lands (OCCL) issues Site Plan Approval. CMS will comply with any and all conditions issued by OCCL.

V. Comprehensive Management Plan Compliance

The request is consistent with the 2022 Comprehensive Management Plan (CMP), approved by the Board of Land and Natural Resources. In fulfillment of the CMP's community review requirements, the proposed use was or will be presented for consultation as follows in addition to the Maunakea Management Board:

- January 8, Maunakea Environment Committee. No concerns or objections.
- February 12, Mauna Kea Stewardship and Oversight Authority.

Further, CMS' review of the project fulfills the following CMP actions:

- Natural Resources (NR)-1: Limit threats to natural resources through management of permitted activities and uses.
- Education and Outreach (EO)-2: Require orientation of users.
- EO-7: Continue and increase opportunities for community members to provide input to cultural and natural resources management activities on Maunakea, to ensure systematic input regarding planning, management, and operational decisions that affect natural resources, sacred materials or places, or other ethnographic resources with which they are associated.
- Astronomical Resources (AR)-1: Operate the UH Management Areas to prohibit activities resulting in negative impacts to astronomical resources.
- Permitting and Enforcement (P)-1: Comply with all applicable federal, state, and local laws, regulations, and permit conditions related to activities in the UH Management Areas.
- P-1: Strengthen CMP implementation by recommending to the BLNR that the CMP conditions be included in any Conservation District Use Permit or other permit.
- P-4: Educate management staff and users of the mountain about all applicable rules and permit regulations.



University of Hawai'i at Hilo
**CENTER FOR
MAUNAKEA
STEWARDSHIP**

200 W. Kawili Street
Hilo, HI 96720
cmshilo@hawaii.edu
(808) 933-0734



UNIVERSITY
of HAWAII®
HILO

VI. CMS Recommendation

CMS recommends MKMB approve this request proceed to MKSOA and OCCL review with the standard project conditions in the attached list. The project will not proceed unless OCCL issues Site Plan Approval. CMS will comply with any and all conditions issued by OCCL.

Facility Project Proposal for the UH-Managed Lands

for projects anticipated to be classified as having “Minimal Impact”

Proposals due by the 15th monthly

Please mark all that apply to your project

Y Project was reviewed in a 3-Year Plan

Y Project is a CMP, lease, or sublease compliance measure (e.g., keeps the site in safe working order)

Y Project involves heavy machinery (crane and boom/scissor lift)

No Project requires ground disturbance such as digging or trenching

No Project will result in a change to the facility footprint

No Project affects a viewplane (e.g., starline or oceanic gridline)

Facility Name

Subaru Telescope

Brief Descriptive Title of Project

Recoating the Subaru Telescope lower enclosure structure and replacement of two roof-mounted HVAC exhaust outlets

Project Description

The proposed work is needed to address facility damage caused by the tropical storm in August 2024 and consists of two components:

1. Recoating of the exterior of the Lower Structure and Elevator Tower.
2. Replacement of two roof-mounted HVAC Chiller Exhaust Outlets.

Proposed Commencement Date

Estimated between April and August 2026.

Proposed Completion Date

Estimated two months from commencement.

Estimated Project Cost

\$860,200

Total size / area of proposed use

The attached site plan application addresses the onsite placement of construction-related equipment including two, 12' dumpsters, a crane, and a boom- or scissor-style lift for the duration of the project, anticipated to be sixty (60) days. Actual area depends on the equipment rentals available at the time project mobilizes.

The actual project work involving exterior recoating or repainting and the replacement of two upper exhaust vents is assessed to be within normal permissible maintenance not subject to

Conservation District rules. Nevertheless, the approximate area of the lower structure and elevator tower to be recoated is about 16,800 square feet. The two, roof-mounted HVAC chiller exhaust outlets will be replaced with slightly smaller units with a base measuring roughly 63 square feet. Since each existing outlet is approximately 9 feet wide, 9 feet long, and 6 feet high and replacement units are approximately 7 feet wide, 9 feet long, and 5 feet high, the replacements are smaller than the originals (in total, about 65% of the volume of the existing vents).

Project Purpose and Need

The work is needed as soon as possible to prevent further deterioration and damage to the building, originally caused by Tropical Storm Hone.

The lower structure and elevator tower will continue to degrade until the new coating system is applied. The coating system serves both functional and aesthetic purposes. Functionally, it shields the siding materials from moisture, sunlight, and temperature and weather extremes. A new coating system is also easier to clean, more resistant to wear, and less prone to cracking and deterioration. The proposed coating system will further support energy efficiency because white paint reflects sunlight more effectively, and it may offer scientific advantages by providing a lower emissivity rating.

The existing exhaust outlets are subject to additional damage from high winds if they are not replaced, and one of the existing outlet structures was damaged during Hurricane Hone, a Category 1 storm in 2024. These outlets are passive components that are not connected to power or any other building infrastructure. They provide a path for ventilation air to exit the building from the chiller. Replacing the damaged exhaust outlets will result in a safer facility, as the new components will be designed for site specific environmental conditions and current building codes, and will be engineered and manufactured to withstand wind forces equivalent to a Category 5 hurricane. This improvement will significantly enhance structural durability and long-term reliability under extreme wind conditions.

Has professional peer-review occurred

Yes; the design was prepared by Hawaii professionals licensed in architecture and engineering. The coating system was reviewed by a coatings specialist and test mockups were completed. The exhaust outlets will also be reviewed by the County of Hawaii Building Department for conformance with the applicable building codes.

Are there any related ongoing, pending, or planned projects associated with this submission?

Yes; a related and ongoing project, "Repairment of the dome and roof to prevent rain leaks and airtightness degradation," was necessary to repair other facility damage caused by Tropical Storm Hone. Work is in underway for that project, approved November 2024 via OCCL concurrence.

Description of the Project

Location

The recoating work will occur on the elevator tower and the lower dome structure, below the rotating enclosure. The two exhaust outlets are located on the roof of the stationary lower structure. Reference the following diagrammatic image.

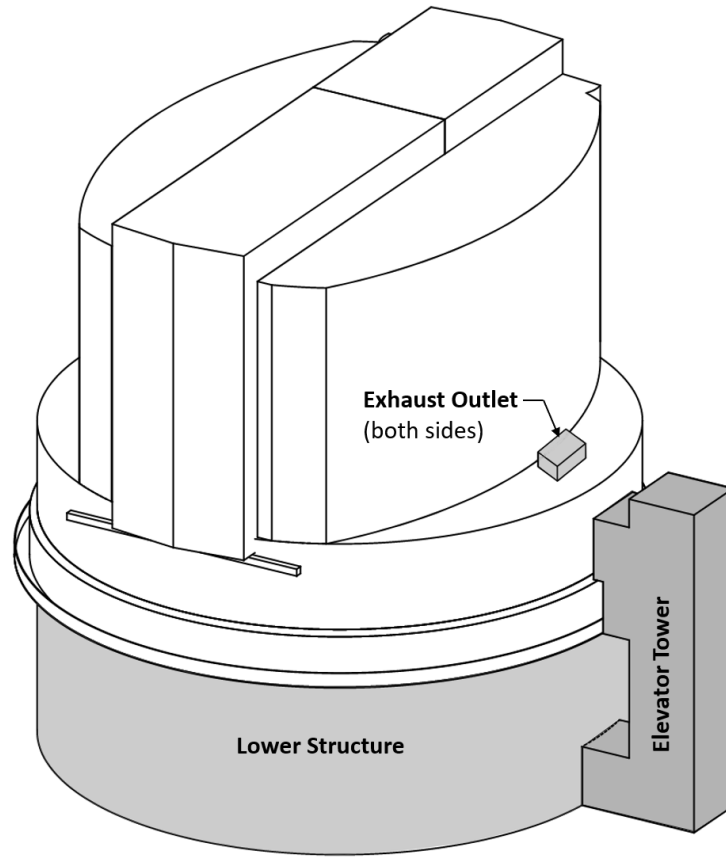

Description of the process of completing the project

1. Recoating of the of the Lower Structure and Elevator Tower.

Surface preparation will include inspection, removal of loose and flaky coating, solvent and hand tool cleaning, and a final alcohol wipe, with power tool cleaning performed (where required at the large overhead steel door only). The recoating will use a three-coat system consisting of two base coats of PPG Amercoat 370 epoxy followed by a topcoat of PPG Amershield VOC polyurethane with accelerator. All coatings will be applied in accordance with manufacturer recommendations, and the final color will match the existing Arctic Ice (white) finish. The existing coating systems does not contain asbestos or lead based paints.

The recoating work will begin with mobilization of personnel, equipment, and materials, along with establishment of work zones and implementation of all required safety and environmental controls under a contractor prepared Health and Safety Plan. A third-party environmental monitoring firm will oversee compliance throughout the project. Their responsibilities will include reviewing safety and environmental plans, conducting baseline sampling, performing continuous air monitoring during surface preparation, observing containment and dust control practices, and completing post activity sampling to confirm that conditions meet clearance criteria.

Before coating work begins, site preparation will include installation of Best Management Practices to protect the surrounding environment. These measures will include ground covers to capture debris, secondary containment for equipment with potential fluid leaks, and additional controls such as berms or absorbents as needed. Surface preparation will not involve sandblasting. Instead, all coating work will use low impact methods, and the coating system will be applied exclusively with paintbrushes and hand rollers. Personnel will utilize bucket lifts to access elevated work heights. Work will progress methodically around the structure, and daily inspections will verify dry film thickness and adhesion in accordance with manufacturer requirements.

After the topcoat has cured, a final inspection will confirm coating quality, surface cleanliness, and compliance with environmental and project requirements. All waste, temporary controls, and materials will be removed from the site and disposed of properly. Upon project acceptance, demobilization will occur, restoring the work area to its original condition.

Below is a photo showing the current condition of the coating system, along with an image of the test coating that represents the final coating product.



2. Replacement of two roof-mounted HVAC Chiller Exhaust Outlets.

The two roof mounted exhaust outlets will be replaced in their entirety. The existing units will be removed from the site using an overhead crane. New outlets will be fabricated off site and will be ready for installation immediately after removal of the existing units, using the same crane for placement.

The replacement outlets will be installed on the existing structural support system, which includes the steel framing and mounting components already in place. The new assemblies will be designed to integrate with these supports and to meet current performance and code requirements. Although only one outlet sustained damage, both will be replaced to ensure uniformity and long-term reliability.

Below is a photo showing the current condition of the exhaust outlets, followed by an image of the design for the replacement outlets.



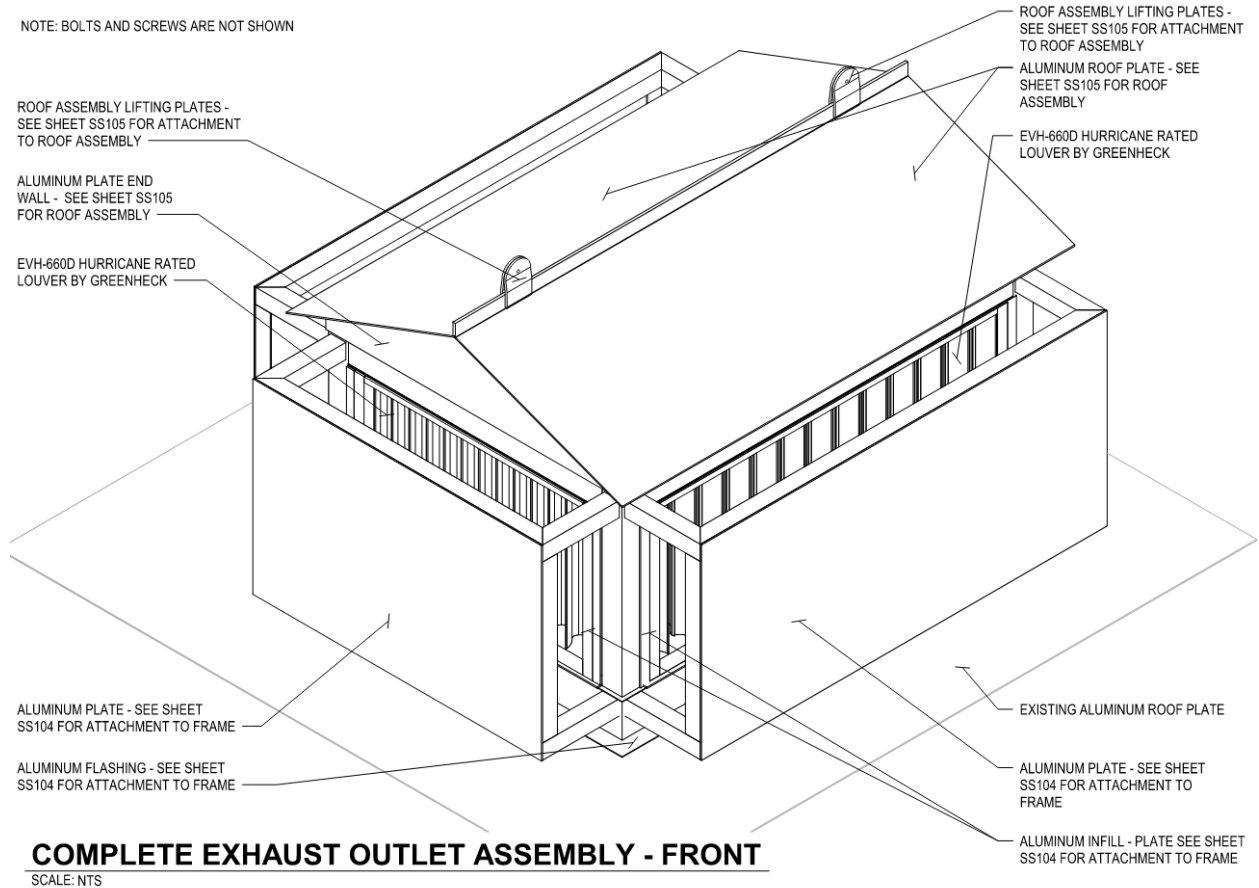

Who will do the work?

A registered general contractor will perform the work with oversight from Subaru staff and the licensed architects and engineers who designed and specified it.

Equipment & Transportation

1. Recoating of the of the Lower Structure and Elevator Tower.

- Aerial lift (articulating boom lift or scissors lift) will be used for painters to access elevated heights.
 - This equipment will be left outside.
- Spill berms and drip pans for aerial lift staging areas.
- Air monitoring equipment.
- Ground cover materials and containment supplies.
- Secondary containment systems.
- Masking materials.
- Brushes and hand rollers.
- Basic surface preparation tools.
- Waste handling equipment.
- Debris handling containers.

2. Replacement of two roof-mounted HVAC Chiller Exhaust Outlets.

- Lift and Rigging Equipment: Site crane for lifting and removing existing outlets and placement of new outlets.
 - This equipment will be left outside.
- Temporary support stands or cribbing.
- Tools for disassembly and installation (powered hand tools).
- Safety Equipment: fall protection systems, PPE
- Spill berms and drip pans for crane and manlift staging areas.
- Debris handling containers.

Measures to protect the environment and/or mitigate impacts

Impacts

No impacts expected.

Compliance with Lease, Sublease, or Comprehensive Management Plan (CMP)

The project is a sublease compliance action.

Identify other required or associated permits

N/A

Community Benefits

Benefits to other Maunakea entities and/or global astronomy community

N/A

Benefits to the Hawaii Island community

N/A

Will data, publications, or other products be free and available to the public?

N/A

For internal use only by CMS

Review checklist

Staff review and report

Outside agency review or approval required

Environment committee, if environmental impacts are anticipated

3YP_ Kahu Ku Mauna, if cultural impacts are anticipated and KKM requested consultation, or the project was not included in a 5YP or 3YP

Maunakea Management Board

Project approval conditions

Prepare to Start the Project

- Identify and comply with other permit requirements, such as County of Hawai'i building permits or Department of Land & Natural Resources permits (see *both*/any applicable DLNR permit and [HAR §13-5-42 Standard conditions](#)).
- Use of real-time GPS during any surveying or equipment operation requires advance written approval from CMS and the Institute for Astronomy. GPS use should be requested at least four (4) weeks prior to the proposed activity.
- Any required Best Management Practices, Communication Plans, contract scope questions, etc. must be finalized and approved by CMS prior to final approval.
- CMS will provide a final, written notice explicitly stating whether the project is approved to commence (i.e., issue a "Notice to Proceed"). The Notice to Proceed will include any additional, project-specific conditions. **No project work may commence before this time.**
- Project approval may not be transferred or assigned without prior authorization. A copy of the approval/permit must be present on-site and available for review at all times while working on UH-managed lands.
- Applicant shall comply with all actions and measures described in the proposal, including (community) benefits, CMP compliance list, and mitigation measures.

Notifications

- Applicant may request to arrange a pre-construction meeting with CMS before work commences. These meetings review orientation content, implications of project non-compliance, project-specific concerns regarding resource protection, health and safety, visitor and/or traffic impacts, etc. Meetings may be held in person or via phone, webinar, or other means.
- Notify CMS in writing via email to cmshilo@hawaii.edu at least five (5) days prior to beginning field work on UH-managed lands (Halepōhaku, Road Corridor, Maunakea Science Reserve, or Astronomy Precinct) with the following:
 - Identify the date that onsite work will commence.
 - Identify by name-of-entity all observatories, contractors, vendors, suppliers, etc. anticipated to be associated with and substantively present on UH-managed lands for the project.
 - Identify the individual(s) who will be coordinating all invasive species inspections.
 - Attest that the observatory or relevant entity will ensure compliance with all permit conditions and communicate with CMS if there is any uncertainty.
 - Notify CMS in writing of any other entities responsible for elements of compliance.
 - Attest that all individuals anticipated to be associated with the project have completed the Maunakea User Orientation.
 - CMS is not liable or responsible for delays due to inadequate or late submissions or submissions requiring verification.

Onsite Activity

General

- Use of lighting from sunset to sunrise is prohibited unless described in the project proposal and approved.
- Use of cell-phones, other than in airplane mode, is prohibited except in case of emergency.
- Placement of permanent markers, monuments, mag nails, or survey pins, etc. is not allowed without explicit prior approval from CMS (and the State if required). ALL surveyors' work must be shared with CMS in digital format with coordinate info stored in and using a common, transferrable coordinate reference system such as "State Plane Coordinates (NAD83), Hawai'i Zone 1".
- Allow CMS Rangers to visit and monitor activities.

Transportation and Motorized Equipment

- No use of mechanized equipment is allowed unless authorized by this permit.
- 4-wheel-drive required for travel above Halepōhaku.
- Large, heavy, non-4-wheel-drive or oversized loads must submit notification to the Maunakea Road Conditions listserv, MK-ROAD-CONDITIONS@lists.hawaii.edu, at least one day prior to transit. Loads requiring an escort on public roadways must have this escort accompany them to the final destination. Projects failing to submit notification or arrange for escort to the summit may be denied entry to Halepōhaku or above.
- During public closures of the Summit Access Road, vehicle access above Halepōhaku is limited to explicitly-marked observatory, CMS, federal, or state of Hawaii vehicles. Vehicles must be operated by approved employees or representatives on official business and possessing requisite orientation, training, safety, and rescue supplies.
- Motorized equipment, when stationary, must have a drain-pan in place suitable for catching fuel or fluid leaks.

Debris Prevention and Severe Weather Concerns

- Ensure that any debris, tools and equipment are secured to avoid becoming windblown and are properly stored at the end of each day.
- Projects occurring in the summit region must verify that temporary and permanent infrastructure and improvements can sustain 120 MPH winds and severe weather.

Environmental Concerns

- All perishable items including food, food wrappers, and containers must be removed from the site daily and properly disposed of.
- Remove and properly dispose of all waste material.
- Nēnē (*Branta sandvicensis*) may be present. If a nēnē appears within 100 feet (30.5 meters) of ongoing work, all activity shall be temporarily suspended until the animal leaves the area of its own accord. Federal law prohibits feeding or any "taking" (e.g., harassing, harming, killing) of nēnē.
- Best Management Practices for seabirds, including the endangered Hawaiian petrel (*Pterodroma sandwichensis*)
 - Use red light bulbs outside to the maximum practicable extent.
 - Fully shield outdoor bulbs so the light is only visible from below.
 - Install motion sensors or turn off lights when human activity is not occurring in the area.

- September-December: Avoid nighttime construction.
- Best Management Practices for the endangered Hawaiian Hoary Bat (*Lasiurus cinereus semotus*)
 - No barbed-wire fencing allowed.
 - June-November: Do not trim, remove, or disturb trees over 15 feet tall.

Invasive Species Prevention

- Employ invasive species prevention best practices, including inspections of materials by a DLNR-approved biologist, as identified in the Maunakea Invasive Species Management Plan prior to entering UH-managed lands.
 - Inspections can only occur at locations where landowners have given permission (i.e. facilities, baseyards, and vendor locations).
 - Inspections shall not occur on UH-managed lands on Maunakea, at State or County parks, along public roadsides, or on Department of Hawaiian Homelands lands.

Upon Project Completion

- The project must be completed within the time frame specified in the proposal and, when applicable, as specified by DLNR. Projects that cannot be completed within this timeframe are not allowed to continue (or commence) without explicit prior written approval from CMS.
- Notify CMS in writing when field activity associated with the project is completed.
- Unless otherwise stated in the proposal, copies of all data, field notes, photos, log books, collected specimens, and other forms of documentation will be shared with CMS for future, unrestricted use by CMS or its designee. All geospatial data, metadata or applications must be in a format compatible with CMS GIS software or other industry standard identified in advance.
- Collected specimens that are not consumed in analysis will be returned to CMS unless otherwise specified.
- Provide CMS with electronic and paper copies of all publications resulting from the work. When applicable, annual, final reports must be submitted to CMS.
- When applicable, a brief, approximately 1-page, non-technical summary suitable for public outreach (school groups, community meetings, newsletter articles, etc.) must be provided to CMS within 90 days of project completion or publication. Photos and illustrations are encouraged.



SITE PLAN APPROVAL APPLICATION (SPA)

File No:

Acceptance Date:

30-Day Expiration Date:

Assigned Planner:

for DLNR Use

Pursuant to Hawai'i Administrative Rules (HAR) §§13-5-22 through 24, identified land uses beginning with letter (B) require a site plan approval by the department.

PROJECT NAME: Recoating the Subaru Telescope Lower Enclosure Structure and Replacing Two Roof-Mounted HVAC Exhaust Outlets

Conservation District Subzone: Resource

Identified Land Use: HAR § 13-5-22, Protective subzone, P-9, Structures, Accessory (B-1) Construction or placement of structures accessory to existing facilities or uses...

(See Hawai'i Administrative Rules (HAR) §13-5-22 through §13-5-25)

Project Address: Subaru Telescope, Maunakea summit area

Ahupua'a, District, Island: Ka'ohe mauka, Hamakua, Hawaii Island

Tax Map Key(s): 3-4-4-015:009, Mauna Kea Science Reserve (por.)

Proposed Commencement Date: Between April and August 2026

Proposed Completion Date: Two months from commencement

Estimated Project Cost: \$860,200

Total area of proposed use: Outdoor equipment storage is needed for the 1-2 dumpsters, a crane, and a lift associated with the facility work; exact area TBD.

ATTACHMENTS

- \$50 application fee (*ref §13-5-32 through 34*)
- Location map
- Site plan
- Construction, grading, site restoration, landscaping, or fire buffer plans, as applicable

Note: The application fee for State projects is waived pursuant to HAR §13-5-32.

REQUIRED SIGNATURES

Applicant

Name: Subaru Telescope
Title; Agency: Subaru Telescope, National Astronomical Observatory of Japan
Mailing Address: 650 North A'ohoku Place, Hilo, Hawaii 96720
Contact Person & Title: Dr. Satoshi Miyazaki, Director
Phone: 808-934-5964
Email: satoshi@naoj.org
Interest in Property: Sublessee to General Lease S-4191; original site CDUP HA-2462

Signature: _____ Date: _____
Signed by an authorized officer if for a Corporation, Partnership, Agency or Organization

Landowner (if different than the applicant)

Name: State of Hawai'i (managed by University of Hawai'i under General Lease S-4191)
Title; Agency: Greg Chun, Executive Director, Center for Maunakea Stewardship
Mailing Address: c/o University of Hawai'i at Hilo, 200 West Kawili Street, Hilo, HI 96720
Phone: 808-933-0734
Email: cmshilo@hawaii.edu

Signature: _____ Date: _____
For public lands, the government entity with management control shall sign as landowner.

Agent or Consultant

Agency: N/A
Contact Person & Title: Click or tap here to enter text.
Mailing Address: Click or tap here to enter text.
Phone: Click or tap here to enter text.
Email: Click or tap here to enter text.

Signature: _____ Date: _____

For DLNR Managed Lands

Chairperson, Board of Land and Natural Resources
P.O. Box 621
Honolulu, Hawai'i 96809-0621

Signature: _____ Date: _____

PROPOSED USE

Total size/area of proposed use (indicate in acres or sq. ft.): At least 96 sq ft, for two, 12' dumpsters

Please provide a detailed description of the proposed land use(s) in its entirety. Information should describe what the proposed use is; the need and purpose for the proposed use; the size of the proposed use (provide dimensions and quantities of materials); and how the work for the proposed use will be done (methodology). If there are multiple components to a project, please answer the above for each component. Also include information regarding secondary improvements including, but not limited to, grading and grubbing, placement of accessory equipment, installation of utilities, roads, driveways, fences, landscaping, etc.

The actual project, to recoat part of the Subaru dome and replace exhaust vents, occurs wholly upon the Subaru facility and is regular maintenance work not considered to be a land use subject to Conservation District Rules. However, the work requires the outdoor placement of items supporting the project, potentially for up to two months, which is subject to Conservation District rules. Equipment to be stored outdoors include:

- (Minimum 96 sq ft) Up to two, 12'x8' dumpsters to securely store project debris
- One crane
- One boom- or scissor-style lift

PROPOSED EXEMPTION

An exemption from needing an environmental assessment (EA) refers to specific situations or projects that are not required to undergo the standard EA process due to their minimal potential impact on the environment.

Government agencies should use the appropriate exemption list as concurred by the Environmental Advisory Council as found at planning.hawaii.gov/erp/agency-exemption-list

Private parties should use DLNR's Exemption List as concurred by the Environmental Council on November 10, 2020 as found at files.hawaii.gov/dbedt/erp/Agency_Exemption_Lists/State-Department-of-Land-and-Natural-Resources-Exemption-List-2020-11-10.pdf

The project is considered exempt under HAR §11-200.1-15 (c)(2) Replacement or reconstruction of existing structures and facilities where the new structure will be located generally on the same site and will have substantially the same purpose, capacity, density, height, and dimensions as the structure replaced. The project is also considered exempt under HAR §11-200-8(a), Exemption Class #1: Operation, repair or

maintenance of existing structures, facilities, equipment or topographical features, involving negligible or no expansion or change of use beyond that previously existing; (2) Painting and re-roofing of existing buildings; and Exemption Class #2: Replacement or reconstruction of existing structures and facilities where the new structure will be located generally on the same site and will have substantially the same purpose, capacity, density, height and dimensions as the structure replaced. (1) Replacement or reconstruction of: (m) Air conditioning and ventilation systems.

EXISTING CONDITIONS

Please describe existing conditions on the parcel (geology, ecology, cultural and recreational resources, historic resources, structures, landscaping, etc). Provide information regarding existing buildings and structures as well as infrastructure and utilities as applicable.

The project site is the Subaru Telescope, where the soil is previously excavated backfill. Natural hazards may include fire and seismic activity. Maunakea is considered dormant, with very low risk of eruption at the summit. The site is not designated within any Flood Hazard Safety Area nor within a Tsunami Evacuation Area. Hazards more commonly encountered are weather-related hazards such as freezing temperature, falling icicles, diminished visibility due to sun glare or fog, and black ice; or are due to high-altitude related conditions and illness.

Climate, Soils, Geology, Hydrology

The project site is near the summit of Maunakea at an elevation of approximately 13,000 feet above Mean Sea Level. The climate is alpine desert, with minimum temperatures around 0 Celsius in the summer and -4 Celsius in the winter. Mean annual precipitation is 15 cm (primarily snowfall).

Soil at the project site include excessively drained soil in the form of ash, cinder, clinker and lava flow following 2-40 percent slopes.

Surface water: The nearest surface water body is Lake Waiau, roughly 3/4 mile south of the project site across excessively drained soil. Lake Waiau is an alpine glacier lake fed by precipitation and snowmelt from proximal surrounding surfaces. No groundwater has been identified near the Subaru parcel.

No Flora, Fauna, Ecology, or Water resources will be altered or disturbed. All work is inside except for the articles placed outside on previously disturbed soil.

Subaru is located within the following identified historic properties: Kukahau'ula Traditional Cultural Property, State Inventory of Historic Places (SIHP) Site #50-10-23-21438; the Mauna Kea Summit Region Historic District, SIHP #50-10-23-26869; and the Mauna A Wakea Traditional Cultural Property and District, SIHP #31382. There are no identified historic properties within several hundred feet of the project area. Project activity will be limited to the Subaru facility and equipment set outside will be on previously disturbed soil that is regularly used for parking and delivery. No disturbance or impact to any cultural or historic resources are anticipated.

EVALUATION CRITERIA

The Department or Board will evaluate the merits of a proposed land use based upon the following eight criteria (*ref §13-5-30(c)*)

1. **The purpose of the Conservation District is to conserve, protect, and preserve the important natural and cultural resources of the State through appropriate management and use to promote their long-term sustainability and the public health, safety, and welfare. How is the proposed land use consistent with the purpose of the conservation district? (*ref §13-5-1*)**

The proposed project does not negatively impact the level of conservation, protection or preservation of the natural and cultural resources of the site.

2. **How is the proposed use consistent with the objectives of the subzone of the land on which the land use will occur? (*ref §13-5-11 through §13-5-15*)**

The objective of the Resource subzone, where the Subaru Telescope is located, is "...to develop, with proper management, areas to ensure sustained use of the natural resources of those areas." This proposed land use (placement of solid material for more than thirty days) is an allowable use within the Conservation District Resource subzone, pursuant to HAR 13-5-24, R-3, Astronomy Facilities, (D-1), under an approved management plan. The approved management plan is the 2022 Maunakea Comprehensive Management Plan Supplement. In addition to the proposed project being an identified use, both the UH and Subaru are committed to managing the natural and cultural resources of the UH Management Areas in a way that fulfills the objective of the Resource subzone of the Conservation District. The project will facilitate sustained use of the site for existing, approved uses. No change in footprint or type, extent, or intensity of use will occur as a result of this project. Natural and cultural resources will not be negatively impacted.

3. **Describe how the proposed land use complies with the provisions and guidelines contained in chapter 205A, HRS, entitled "Coastal Zone Management" (*see 205A objectives on p. 7*).**

The site of the proposed use is over 20 miles from the coast and is not connected to shoreline resources. The project will have no effect on any of the coastal resources identified in 205A, including, but not limited to, recreational opportunities, historic resources, scenic and open space, ecosystems, economic uses, beach and coastal dune protection, and/or marine and coastal resources. The project is also not a coastal development. Consequently, the project complies with the objectives of HRS 205A.

4. **Describe how the proposed land use will not cause substantial adverse impact to existing natural resources within the surrounding area, community or region.**

The project is limited to the dome structure within the Subaru parcel, an area disturbed when Subaru was originally constructed. The area is currently used for regular operations including vehicle movement, vehicle parking, and routine maintenance. None of the waste generated is considered hazardous and all waste will be captured and removed from the summit. CMS will ensure the project complies with the 2022 CMP Supplement; all applicable Standard Operating Procedures of the Maunakea Invasive Species Management Plan to ensure that natural resources are not harmed and no invasive species are introduced; conditions recommended by the Environment Committee, Maunakea Management Board, the Mauna Kea Stewardship and Oversight Authority; and approval conditions provided by OCCL.

5. **Describe how the proposed land use, including buildings, structures and facilities, is compatible with the locality and surrounding areas, appropriate to the physical conditions and capabilities of the specific parcel or parcels.**

The project seeks to repair storm damage to the exterior of the facility. This is compatible with the locality and surrounding area as the parcel has already been developed with infrastructure and the project will maintain the capabilities of the parcel. The project will maintain the technical ability of Subaru Telescope will not affect any natural, cultural, or historic resources.

6. **Describe how the existing physical and environmental aspects of the land, such as natural beauty and open space characteristics, will be preserved or improved upon.**

No changes will occur to the existing physical and environmental aspects of the land.

7. **If applicable, describe how subdivision of land will not be utilized to increase the intensity of land uses in the Conservation District.**

No new subdivision of land will occur.

8. **Describe how the proposed land use will not be materially detrimental to the public health, safety and welfare.**

The project bears no negative impact to the public health, safety and welfare and will take measures to maintain public safety.

CULTURAL IMPACTS

Articles IX and XII of the State Constitution, other state laws, and the courts of the State, require government agencies to promote and preserve cultural beliefs, practices, and resources of Native Hawaiian and other ethnic groups.

Please provide the identity and scope of cultural, historical, and natural resources in which traditional and customary native Hawaiian rights are exercised in the area.

The proposed use is located within three historic districts identified on the State Inventory of Historic Places, the Kukahau'ula Traditional Cultural Property, SIHP #21438, the Mauna Kea Summit Region Historic District, SIHP #26869, and Mauna A Wakea Traditional Cultural Property and District, SIHP #31382. There are no identified cultural resources and no historic properties within several hundred feet of the project area. The project site is within the alpine stone desert ecosystem, which significantly limits the abundance and diversity of plant and animal species that can survive here. CMS' invasive species and arthropod monitoring programs provides the most comprehensive reference for species discovered at the project site. Geologically, the project site is composed of local backfilled cinder and rocks. There are no hydrological resources on the site. Additional details provided in the previous "Existing Conditions" section of this application.

Identify the extent to which those resources, including traditional and customary Native Hawaiian rights, will be affected or impaired by the proposed action.

Project activity including the outdoor storage of some bulky equipment and supplies will be limited to within the Subaru sublease area. This area is of previously disturbed soil/cinder that is regularly used for parking, deliveries, and daily maintenance and operations. CMS has not identified any traditional and customary Native Hawaiian rights that may be affected by the project, and the applicant does not anticipate any degree of disturbance or impacts to any cultural, historical, and natural resources, including traditional and customary Native Hawaiian rights.

What feasible action, if any, could be taken by the Board of Land and Natural Resources regarding your application to reasonably protect Native Hawai'i rights?

The applicant defers to the BLNR on feasible actions to reasonably protect Native Hawai'i rights.

CHAPTER 205A – COASTAL ZONE MANAGEMENT

Land uses are required to comply with the provisions and guidelines contained in Chapter 205A, Hawai'i Revised Statutes (HRS), entitled "Coastal Zone Management," as described below:

- **Recreational resources:** Provide coastal recreational opportunities accessible to the public.
- **Historic resources:** Protect, preserve, and, where desirable, restore those natural and manmade historic and prehistoric resources in the coastal zone management area that are significant in Hawaiian and American history and culture.
- **Scenic and open space resources:** Protect, preserve, and, where desirable, restore or improve the quality of coastal scenic and open space resources.
- **Coastal ecosystems:** Protect valuable coastal ecosystems, including reefs, from disruption and minimize adverse impacts on all coastal ecosystems.
- **Economic uses:** Provide public or private facilities and improvements important to the State's economy in suitable locations.
- **Coastal hazards:** Reduce hazard to life and property from tsunami, storm waves, stream flooding, erosion, subsidence, and pollution.
- **Managing development:** Improve the development review process, communication, and public participation in the management of coastal resources and hazards.
- **Public participation:** Stimulate public awareness, education, and participation in coastal management.
- **Beach protection:** Protect beaches for public use and recreation.
- **Marine resources:** Promote the protection, use, and development of marine and coastal resources to assure their sustainability.

CERTIFICATION

I hereby certify that I have read this completed application and that, to the best of my knowledge, the information in this application and all attachments and exhibits is complete and correct. I understand that the failure to provide any requested information or misstatements submitted in support of the application shall be grounds for either refusing to accept this application, for denying the permit, or for suspending or revoking a permit issued on the basis of such misrepresentations, or for seeking of such further relief as may seem proper to the Land Board.

I hereby authorize representatives of the Department of Land and Natural Resources to conduct site inspections on my property. Unless arranged otherwise, these site inspections shall take place between the hours of 8:00 a.m. and 4:30 p.m.

Signature of authorized agent(s) or if no agent, signature of applicant

AUTHORIZATION OF AGENT

I hereby authorize *Click or tap here to enter text.* to act as my representative and to bind me in all matters concerning this application.

Signature of applicant(s)

EXEMPTION NOTICE FORM

Subaru Telescope
National Astronomical Observatory of Japan
650 North A'ohökū Place
Hilo, Hawai'i, 96720

TO: 1. Agency-Maintained Public Files for Chapter 343 HRS Exemption Determinations
2. Office of Planning and Sustainable Development, if publication is desired
3. Subaru Telescope

FROM: Dr. Satoshi Miyazaki, Director, Subaru Telescope

SUBJECT: Exemption Notice for Re-Coating the Subaru Telescope Lower Enclosure Structure and Replacing Two Roof-Mounted HVAC Exhaust outlets (CMS project #364)

DATE: 2/13/2026

AGENCY OR APPLICANT ACTION

Check applicable box

- This exempted action is an agency action as defined by Section 343-5(b), Hawai'i Revised Statutes (HRS), and Section 11-200.1-8, Hawai'i Administrative Rules (HAR),
- This exempted action is an applicant action as defined by Section 343-5(e), HRS, and Section 11-200.1-9, HAR

EXEMPTION TYPE:

The Exemption Notice for the action described below is based on the general types enumerated in Section 11-200.1-15(c), Hawai'i Administrative Rules (HAR), Exemption Type **(c)(2) Replacement of reconstruction of existing structures and facilities where the new structure will be located generally on the same site and will have substantially the same purpose, capacity, density, height, and dimensions as the structure replaced.**

As applicable, the exemption for the action described below is also supported by the Exemption List for the [University of Hawai'i], reviewed and concurred to by the Environmental Council on 2001].

- Exemption List Class **1 and 2**.
- Item Number **2 and 1m**.
- Applicable language from the exemption list: Painting and re-roofing of existing buildings (Exemption 1/Item 2). Air conditioning and ventilation systems). (Exemption 2/Item 1m).

DESCRIPTION OF ACTION

Proposing Agency or Applicant: Subaru Telescope

Project Name & Address/Location: Subaru Telescope, Mauna Kea Science Reserve, Ka'ohē Mauka, Hāmakua District, Hawai'i

Anticipated Start Date: 4/1/2026

Anticipated End Date: 10/31/2026

Island and District: Hawai'i Hāmakua

Tax Map Key(s) and other geolocation means: TMK (3)4-4-015:009

All Necessary Permits and Approvals: Site Plan Approval, Office of Conservation and Coastal Lands, Department of Land and Natural Resources; County of Hawaii building permit

NARRATIVE

Describe the action and why it qualifies for the exemption: The Subaru Telescope requests to re-coat the lower enclosure structure and replace two HVAC exhaust vents on the dome roof. These are repair measures needed to address damage sustained from Storm Hone. The replacement vents will be roughly a third smaller than the originals. The parcel is subzoned Resource within Conservation District lands and subject to Conservation District Rules. Subaru is an astronomy facility originally permitted under Conservation District Use Permit HA 2462. The proposed use is the onsite placement of construction-related items (up to two dumpsters, one crane, and one manlift) for more than thirty days and is permissible pursuant to Conservation District rules HAR §13-5-22, P-9, Structures, Accessory, (B-1) *Construction or placement of structures accessory to existing facilities or uses*. The proposed use fulfills the objective of the Resource subzone, "...to develop, with proper management, areas to ensure sustained use of the natural resources of those areas." Further, under the terms of Subaru's sublease, effective through December 2033, Subaru shall be responsible for all repair and maintenance of the grounds, buildings and improvements upon the premises. Subaru's sublease also requires the site be maintained pursuant to requirements set by the University's General Lease S-4191; namely, that the site be maintained in good working order. The action is expected to have minimal or no significant adverse effects to any natural (biological, ecological, hydrological, geological), cultural, historic, recreational, or scientific resources.

RECEIVING ENVIRONMENT

Describe the site, including any impacts on the receiving environment: The project site is the Subaru sublease parcel in the alpine stone desert of Maunakea's summit region. Subaru is a permitted astronomy facility that is regularly used and maintained. The main geological features in the region include ash, cinder, clinker, cinder cones, and Hawaiite lava rock. Given the low annual precipitation of 15 cm and the porous substrate, there are no surface water or groundwater resources at or near the site. Flora and fauna at the site may include lichens, mosses, ferns, and over three dozen arthropod species. No rare, threatened, or endangered species have been documented at the site. The Subaru parcel is within three sites listed on the State Inventory of Historic Places: Kūkahau'ula Traditional Cultural Property (SIHP #50-10-23-21438), the Mauna Kea Summit Region Historic District (SIHP #26869), and the Mauna A Wākea Traditional Cultural Property and District (SIHP #31382). There are no identified historic properties within several hundred feet of the project area. The proposed use will not impede any celestial viewplanes or oceanic gridlines that may be visible from the project site. Minimal noise is anticipated by the project and will be limited to power-cleaning of a steel door in preparation for re-coating. Occasional recreational visitors may park at Subaru during the daytime, when heavy machinery (crane, manlift) associated with the proposed use will be in use. Visitors may be blocked from entering the active work area for safety reasons, but only for a brief period, and other summit areas will remain open to public access.

ENVIRONMENTAL ANALYSIS

I have considered the potential effects of the proposed project and all related activities against the criteria checked below:

Land Use and Zoning Conformance Not Applicable

- | | |
|---|-------------------------------------|
| <input checked="" type="checkbox"/> Traffic (Vehicles, Bicycles, Pedestrian) | <input type="checkbox"/> |
| <input checked="" type="checkbox"/> Infrastructure (Roads, Buildings, Utilities) | <input type="checkbox"/> |
| <input checked="" type="checkbox"/> Air Quality Pollutant Emissions | <input type="checkbox"/> |
| <input checked="" type="checkbox"/> Noise Emissions | <input type="checkbox"/> |
| <input checked="" type="checkbox"/> Solid, Hazardous, and Liquid Waste Management | <input type="checkbox"/> |
| <input type="checkbox"/> Social | <input checked="" type="checkbox"/> |
| <input type="checkbox"/> Economic | <input checked="" type="checkbox"/> |
| <input checked="" type="checkbox"/> Health and Safety | <input type="checkbox"/> |
| <input checked="" type="checkbox"/> Recreation | <input type="checkbox"/> |
| <input type="checkbox"/> Public Beach Access | <input checked="" type="checkbox"/> |
| <input checked="" type="checkbox"/> Cultural Resources and Practices | <input type="checkbox"/> |
| <input checked="" type="checkbox"/> Visual/Aesthetic | <input type="checkbox"/> |
| <input type="checkbox"/> Environmental Justice | <input checked="" type="checkbox"/> |
| <input checked="" type="checkbox"/> Rare, Threatened, and/or Endangered Species | <input type="checkbox"/> |
| <input checked="" type="checkbox"/> Surface and Ground Water Resources | <input type="checkbox"/> |
| <input type="checkbox"/> Wetlands | <input checked="" type="checkbox"/> |
| <input type="checkbox"/> Floodplains | <input checked="" type="checkbox"/> |
| <input type="checkbox"/> Riparian/Coastal Resources | <input checked="" type="checkbox"/> |
| <input checked="" type="checkbox"/> Other | <input type="checkbox"/> |

Comments/summary of impact analysis: “Other” criteria considered were potential effects to geological, archaeological/historical, and scientific resources. Subaru is a developed astronomy facility. The site is used for regular scientific operations. Past resource surveys and ongoing monitoring by CMS do not identify any existing historic properties or cultural resources within or near the sublease area, nor any rare, threatened, or endangered species. The only apparent anticipated impact may be slightly delayed transit for Summit Access Road users when Subaru transports oversize/heavy construction loads; and to recreational visitors during construction activity closures of the Subaru parcel. These impacts are expected to be brief, with negligible to minimal effect overall.

MITIGATION

Describe all mitigation measures and best management practices planned to address impacts during the project activities and after project completion: CMS has reviewed the proposed use for conformance with Subaru's sublease, the University's General Lease for the Science Reserve (S-4191), and the state's approved management plan for the Maunakea Lands (Comprehensive Management Plan 2022 Supplement) and determines the use to be compliant with these legal documents and management goals. In addition, the proposed action has undergone public review to identify any resources, threats by this action to those resources, potential mitigations, and any other concerns. The project will not proceed unless and until all applicable approvals are received. The project will adhere to any stated approval conditions, including compliance with Best Management Practices such as limiting work to daylight hours only and appropriate waste handling. In addition, pending all applicable approvals, Maunakea Rangers will conduct site visits to ensure compliance with approval conditions.

CONSULTATION

The following consultations are scheduled regarding the project and this declaration exemption (Name, affiliation, consultation date): Maunakea Environment Committee, January 8, 2026; Maunakea Management Board, February 3, 2026; Mauna Kea Stewardship and Oversight Authority, February 12, 2026; DLNR Office of Conservation and Coastal Lands, February 13, 2026.

EXEMPT DECLARATION

The direct, cumulative, and potential impacts of the action described above have been considered pursuant to Chapter 343, Hawai'i Revised Statutes and Chapter 11-200.1, Hawai'i Administrative Rules. I declare that the action described above will have minimal or no significant impact on the environment and is therefore exempt from the requirement to prepare an environmental assessment.

Signature of Director or Delegate

Date

This document is to be kept on file in the agency's records and made available for public review

- Please check here if this document is being submitted to the Office of Planning and Sustainable Development for voluntary publication in *The Environmental Notice*